



OPTIWAVE 8300 C Marine Technical Datasheet

Non-contact Tank Level Radar (FMCW) for cargo level gauging

- Redundant ullage indication
- Fully Stand Alone unit with touch screen
- Completely non-contacting to cargo and vapours
- Closed tank service and cleaning of all components
- Designed to operate in extremely rough conditions on ships

Technical data

Measuring data

Measuring range	0...40 m / 0-132 ft
-----------------	---------------------

Measuring accuracy

Accuracy (at reference conditions)	up to 20 m / 66 ft \leq 2 mm / 0.08" 20...40 m / 66...132 ft \pm 0.01% of distance
Repeatability	\leq 0.5 x error of measurement
Measured value resolution	0.1 mm / 0.04"

Radar principle

Operating mode	FMCW (Frequency Modulated Continuous Wave) 24 GHz
Beam angle	\pm 5°
Local display	Graphical LCD with touch screen

Ambient conditions

Hazardous locations	Intrinsically safe, zone 0, 1, 2; Temperature classes: T6...T1 Explosion groups: IIA...IIC
Ambient temperature (signal converter)	-40...+70 °C / -40...+160 °F
Flange temperature	-40...+200 °C / -40...+390 °F; optional -60...+250 °C / -75...+480 °F
Ingress protection (signal converter)	IP67 (and IP66)

Product conditions

Media	measures all liquids and solids
Physical properties	no effect on measurement results
Dielectric constant	\leq 1.5
Product limitations	liquid ammonia (NH ₃), liquid hydrogen (H ₂); Liquid helium (He)
Process temperature	unrestricted (but beware ambient and flange temperatures)

Materials

Signal converter	stainless steel 316L
Flange system / antenna	stainless steel 316L (1.4404) (standard) or 3% Molybden Mo
Gaskets	FPM (Viton), Karlez 6375 (others optional)
Process connection	DIN 2501 DN 125 / PN 16 (standard) or ANSI B16.5 8", 150 lbs, RF

Power supply and output

Powered by	4-20 mA
Protocols	HART®
Current output	4-20 mA passive

Certificates and approvals

Ex approvals	Intrinsically safe according to ATEX and IEC
IACS approvals	DNV, ABS, GL, LR, BV, CCS, NK, RINA, KR

The OPTIWAVE 8300 C Marine is a highly accurate and reliable instrument for reading the level/ullage. With its heavy duty stainless steel housing, it is submersible (IP67) and designed for installation on main deck. It has stand-alone operation, and is independent of any main monitoring system. It carries also a back up display as standard, for redundant indication locally.

DN125 standard flange / Dimensions and Weights

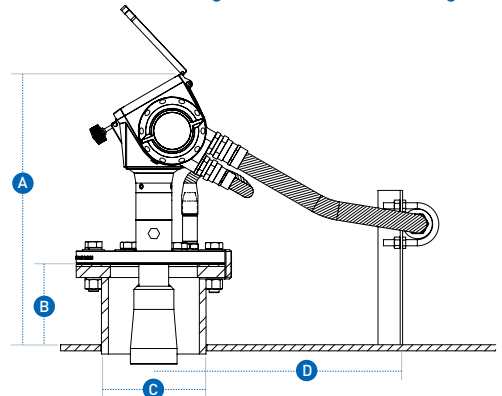

Dimensions (mm)				Weight (kg)	Dimensions (inches)				Weight (lbs)
A	B	C	D		A	B	C	D	
433	141	170 Ø	400	20	17	5.6	6.7 Ø	16	44

Redundant level indication



- Ullage/level will always be shown locally, even with a malfunctioning system
- You will be able to load cargo using only the instrument
- The radar is equipped with touch screen user interface
- Why should you go offshore due to a computer problem?

Closed tank cleaning



- Connect cleaning hose to quick coupling on ball valve
- Open ball valve
- The antenna will be cleaned thoroughly
- Close valve
- Tank is closed during all cleaning

Closed tank service



- Disconnect the main cable
- Disconnect the inert gas pressure cable
- Unbolt the radar
- Install new radar unit on existing bottom part
- Run empty tank spectrum for optimum accuracy

For further technical details, please contact KROHNE Skarpenord.